

1.0 Berechnungseinheiten, Maßeinheiten-Umwandlung

1.1 Berechnungseinheiten	SI Units (N, mm, kW...)			
1.2 Maßeinheiten-Umwandlung				
Länge	1	m	39.37007874	inch
Fläche	1	m ²	1550.0031	inch ²
Dichte	1	kg/m ³	0.062427961	lb/ft ³
Masse	1	kg	2.204624	lb
Trägheit/Verharrungsv	1	kg·m ²	23.73037	lb·ft ²

Geschwindigkeit	1	m/s	3.280839895	ft/s
Beschleunigung	1	m/s ²	3.280839895	ft/s ²
Umdrehungen	1	/s	6.283185307	rad/sec
Kraft	1	N	0.224809	lbf
Moment	1	Nm	0.737561	lbf·ft
Leistung	1	kW	1.34102209	HP
Energie	1	J	0.737562149	ft·lbf
Druck	1	MPa	0.145037	kpsi

2.0 Konzept und Berechnung des Trägheitsmoments und der Abmessungen des Schwungrads

2.1 Vorläufiges Konzept des Trägheitsmoments des Schwungrads

2.2 Typ der Maschine	01. Dieselmotor 4-Takt, 1 Zylinder: [C = 63]		
2.3 Konstante "C" für Konzept "I"	C	63.00	[~]
2.4 Nennleistung der Maschine	Pw	11	[kW]
2.5 Drehzahl des Schwungrads	n	4000.00	[/min]
2.6 Ungleichförmigkeitsgrad	δ	0.0100	[~]
2.7 Trägheitsmoment	I	0.2338875	[kg·m ²]

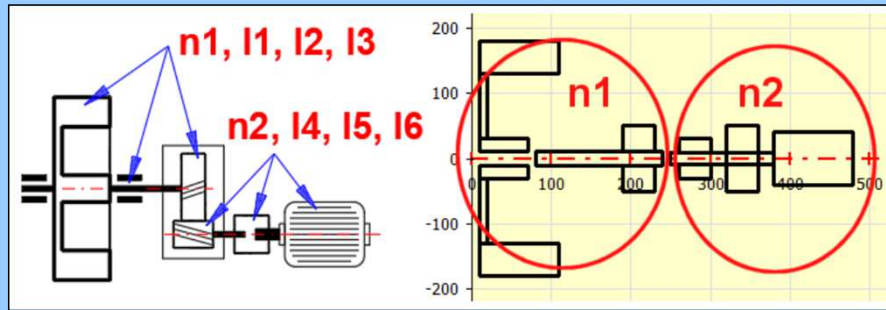

2.8 Vorläufiges Konzept der Schwungradabmessungen

2.9 Soll-Trägheitsmoment	I	0.2338875	[kg·m ²]
2.10 Dichte des Schwungradmaterials	Ro	7800	[kg/m ³]
2.11 Verhältnis Breite/Höhe des Schwungradkranze	x	1.5	[~]
2.12 Innendurchmesser	d	200.000	[mm]
2.13 Außendurchmesser	D	283.617	[mm]
2.14 Breite	b	62.712	[mm]
2.15 Höhe	h	41.808	[mm]
2.16 Gewicht	m	15.536	[kg]
2.17 Trägheitsmoment	I	0.233887497	[kg·m ²]

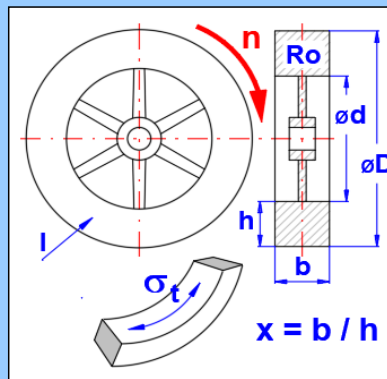

2.41 Diagramm

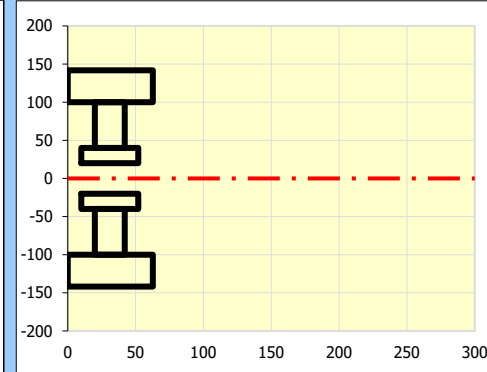

2.18 Maximale Drehzahl, maximale Spannung

2.19 Maximal zulässige Spannung	otmax	100.000	[MPa]
2.20 Poissonzahl	v	0.300	[~]
2.21 Drehzahl des Schwungrads	n	4000 < 7984	[/min]
2.22 Winkelgeschwindigkeit	ω	418.879	[rad/s]
2.23 Tangentiale Spannung am Innendurchmesser	ot	25.100	[MPa]
2.24 Übertragung der Werte in die Tabellenzeile:	1		

2.25 Abmessungen und Berechnung des Schwungrads (der Trägheitsmassen)

ID	Anzahl der	a	D	d	b	Ro	v	n	ω	rg	m	I	Ired	Ek	r	σt
	[-]	[mm]	[mm]	[mm]	[mm]	[kg/m ³]	[~]	[/min]	[rad/s]	[mm]	[kg]	[kg·m ²]	[kg·m ²]	[J]	dx [mm]	[MPa]
1	1	0	283.6166	200	62.71246	7800	0.3	4000	418.879	122.698	15.53574	0.233887	0.233887	20518.91	200	25.10042
2	1	20	200	80	22	7800	0.3	4000	418.879	76.15773	4.528417	0.026265	0.026265	2304.208	80	11.67403
3	1	10	80	40	42	7800	0.3	4000	418.879	31.62278	1.235023	0.001235	0.001235	108.3483	40	1.902333

4	1	0	0	0	0	7800	0.3	1000	104.7198	---	0	0	0	0	0	---
5	1	0	0	0	0	7800	0.3	1000	104.7198	---	0	0	0	0	0	---
6	1	0	0	0	0	7800	0.3	1000	104.7198	---	0	0	0	0	0	---
7	1	0	0	0	0	7800	0.3	1000	104.7198	---	0	0	0	0	0	---
8	1	0	0	0	0	7800	0.3	1000	104.7198	---	0	0	0	0	0	---
9	1	0	0	0	0	7800	0.3	1000	104.7198	---	0	0	0	0	0	---
10	1	0	0	0	0	7800	0.3	1000	104.7198	---	0	0	0	0	0	---
11	1	0	0	0	0	7800	0.3	1000	104.7198	---	0	0	0	0	0	---
12	1	0	0	0	0	7800	0.3	1000	104.7198	---	0	0	0	0	0	---

Σ 21.2992 0.26139 0.26139 22931.5

2.26 Ankerbeln des Schwungrads

2.27 Trägheitsmoment	I	0.26138734	[kg*m²]	<input checked="" type="checkbox"/>
2.28 Anfangsgeschwindigkeit	n1	0	[/min]	
2.29 Endgeschwindigkeit	n2	4000	[/min]	
2.30 Drehmoment	T	20	[Nm]	
2.31 Energie	E	22930.98859	[J]	
2.32 Zeit bis zum Erreichen von n2	t	5.474483559	[s]	

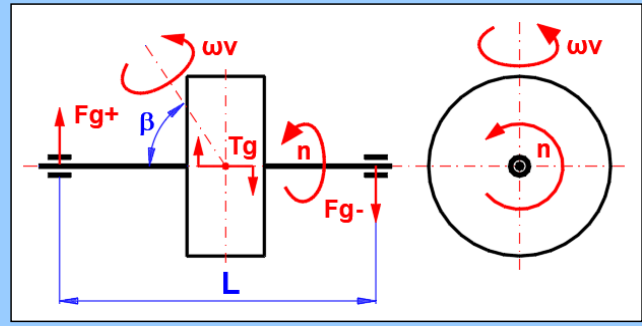

2.33 Kreiselmoment

2.34 Trägheitsmoment	I	0.26138734	[kg*m²]	<input checked="" type="checkbox"/>
2.35 Drehzahl des Schwungrads	n	4000	[/min]	
2.36 Drehachsenwinkel des Schwungrads	β	90	[°]	
2.37 Winkelgeschwindigkeit des Schwungrads	ωv	0.5	[rad/s]	
2.38 Kreiselmoment	Tg	54.74483654	[Nm]	
2.39 Lagerabstand	L	200	[mm]	
2.40 Kraft vom Kreiselmoment	Fg	273.7241827	[N]	

3.0 Analyse (Berechnung) des Schwungrads

3.1 Sollparameter Schwungrad

3.2 Trägheitsmoment	I	0.196962176	[kg*m²]	<input checked="" type="checkbox"/>
3.3 Ungleichförmigkeitsgrad	δ	0.01	[~]	<input type="checkbox"/>
3.4 Mittlere Soll-Drehzahl des Schwungrads	nreq	4000	[/min]	
3.5 Erforderliche mittlere Winkelgeschwindigkeit	ωm	418.879020	[rad/s]	

3.6 Einstellen und Starten der Analyse

3.7 A. Analyse-konstantes Moment (rechte Seite)

3.8 Leistung (Leistungsaufnahme)	P	-10.92119521	[kW]	
3.9 Starten der Analyse				

3.10 B. Analyse-Elektromotor/Generator (rechte Seite)

3.11 Auswahl des Motors / Generators

3.12 Typ des Motors/Generators		3000 / 2p ... 50Hz			
3.13 Empfohlene Nennleistung von/von/bis	P	-13.1	-53.9	[kW]	
3.14 Nennleistung	P	-15		[kW]	
3.15 Betriebsart		Als Motor-Generator			
3.16 Synchrondrehzahl	ns	3000		[/min]	
3.17 Nenndrehzahl	nr	2933	2933	[/min]	<input checked="" type="checkbox"/>
3.18 Nenndrehmoment	Tr	48.84077736		[Nm]	
3.19 Anlaufmoment-Koeffizient	Tzcoeff	2.47	2.47	[~]	

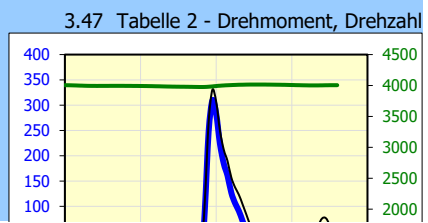
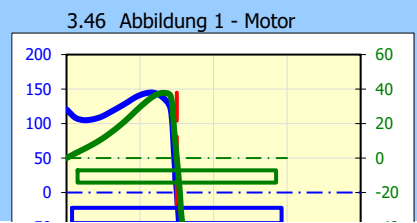
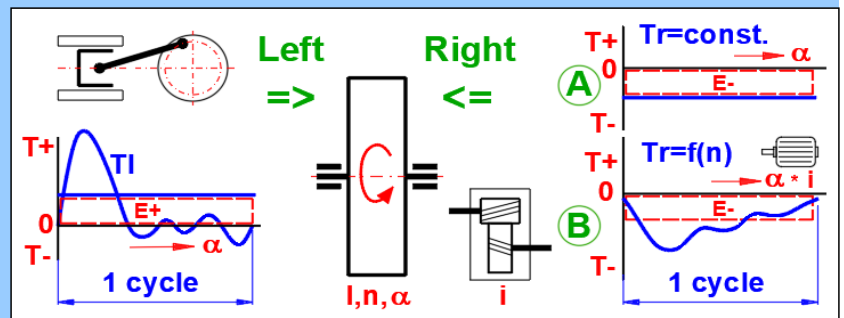

3.20	Anlaufmoment	Tz	120.6367201	[Nm]	
3.21	Trägheitsmoment des Motors / $I_e * i$	Ie	0.068	0.039504	[kg*m ²]
3.22	Übersetzungsverhältnis Schwungrad/Motor	i	0.762	0.762	
3.23	Verwendete Leistung min/max.	P	-14.22	-7.034	[kW]
3.24	Einstellung der Iterationsparameter				
3.25	Anzahl der Iterationsschritte / Empfindlichkeit		10	5	
3.26	Starten der Analyse				

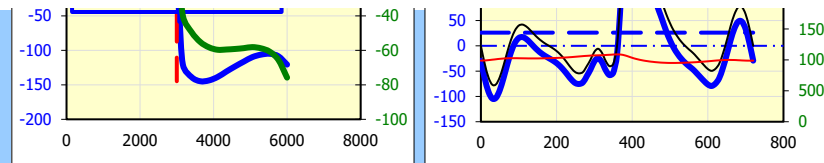

3.27 Ergebnisse der Analyse - B (Elektromotor/Generator)

3.28	Werte von linker und rechter Seite		Links	Rechts	
3.29	Mittleres Drehmoment	Tm	26.07243	-26.18154	[Nm]
3.30	Dem Schwungrad zugeführte Energie	E+	528.8606	0	[J]
3.31	Vom Schwungrad abgeführte Energie	E-	-201.2247	-329.0069	[J]
3.32	Summe aus Energie+/-Abweichung in Prozent	E	-1.6366	-0.50%	[J]
3.33	Schwungrad				
3.34	Mittlere Schwungradrehzahl	n	3995.874	3995.836	[/min]
3.35	Mittlere Winkelgeschwindigkeit	ω_m	418.446958		[rad/s]
3.36	Drehzahl zu Beginn und am Ende des Zyklus	n1,n73	4005.171	4004.981	[/min]
3.37	Minimale / maximale Geschwindigkeit	nmin/max	3975.895	4015.854	[/min]
3.38	Mittlere Schwungradrehzahl	nm	3995.874133		[/min]
3.39	Minimale/maximale Winkelgeschwindigkeit	$\omega_{min/max}$	416.3547	420.5392	[rad/s]
3.40	Mittlere Winkelgeschwindigkeit	ω_m	418.4469607		[rad/s]
3.41	Ungleichförmigkeitsgrad	δ	0.01		[~]
3.42	Trägheitsmoment	I	0.196962176		[kg*m ²]

3.48 Tabelle 3 - Ausgewählte Werte

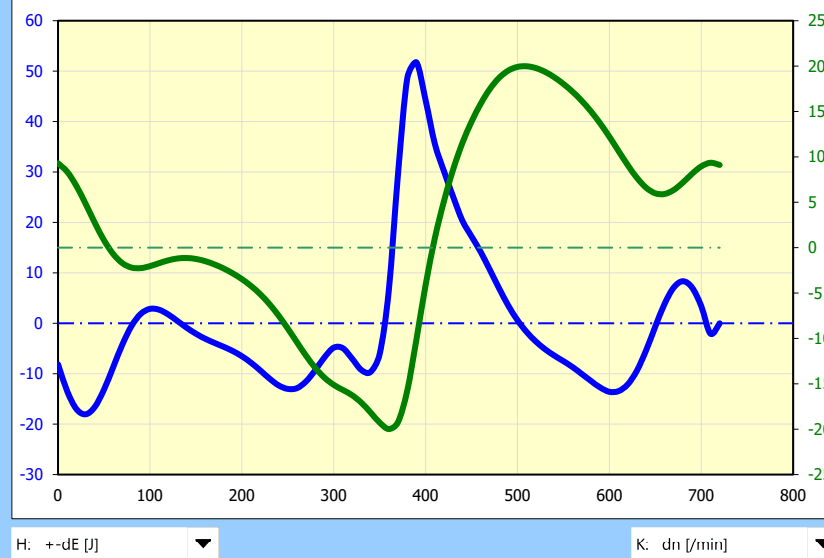

3.43 Definition der Momenten-Tabelle (linke Seite)

3.44	Anzahl der gültigen Zeilen in der Tabelle	nr	73	73	<input checked="" type="checkbox"/>
3.45	Last- und Ergebnistabelle				

ID	A	B	C	D	E	F	G	H	I	J	K	L	M	N	O	P	Q
	Winkel α [°]	Links Tl [Nm]	Eingabe Ti=Ti+Tr [Nm]	Rechts Tr=Te*i [Nm]	Motor ne [/min]	Te [Nm]	Pwe [kW]	+dE [J]	E [J]	n [/min]	dn [/min]	ω [rad/s]	d ω [rad/s]	Pw [kW]	C. Benutzeranalyse		
1	0	0	-29.33033	-29.29332	3052.722	-38.43283	-12.28531	-8.130158	17324.16	4005.171	9.296446	419.4205	0.973522	12.30084	0.000134	-62.3291	-95.14428
2	10	-34.90361	-63.83442	-28.89528	3052.006	-37.9106	-12.11554	-13.4755	17316.03	4004.231	8.35653	419.3221	0.875094	26.76521	0.000134	-62.23829	-95.15765
3	20	-62.3149	-90.58347	-28.23533	3050.818	-37.04474	-11.83422	-16.99524	17302.55	4002.672	6.798161	419.1589	0.711902	37.96607	0.000134	-62.08774	-95.17981
4	30	-76.73453	-104.1676	-27.40264	3049.319	-35.95225	-11.47957	-18.04077	17285.56	4000.706	4.831888	418.953	0.505994	43.63811			
5	40	-76.01871	-102.5644	-26.51827	3047.728	-34.79197	-11.10329	-16.58076	17267.52	3998.618	2.743594	418.7343	0.287308	42.94407			
6	50	-61.70739	-87.43713	-25.70507	3046.264	-33.72504	-10.75763	-13.15952	17250.93	3996.697	0.823339	418.5332	0.08622	36.59264			
7	60	-38.27803	-63.35984	-25.05938	3045.102	-32.8779	-10.48341	-8.696835	17237.77	3995.173	-0.701351	418.3735	-0.073445	26.50613			
8	70	-11.64514	-36.29854	-24.63253	3044.334	-32.31787	-10.30224	-4.205623	17229.08	3994.165	-1.709304	418.268	-0.178998	15.1814			
9	80	12.55172	-11.89435	-24.42607	3043.962	-32.047	-10.21464	-0.523348	17224.87	3993.677	-2.196822	418.2169	-0.230051	4.97405			
10	90	30.31728	5.897216	-24.40038	3043.916	-32.01329	-10.20374	1.862702	17224.35	3993.617	-2.257493	418.2106	-0.236404	-2.466096			
11	100	39.95935	15.44778	-24.49182	3044.081	-32.13326	-10.24254	2.858682	17226.21	3993.833	-2.041557	418.2332	-0.213791	-6.460298			
12	110	41.96243	17.3103	-24.63216	3044.333	-32.31738	-10.30208	2.688162	17229.07	3994.164	-1.710183	418.2679	-0.17909	-7.23981			
13	120	38.27803	13.49377	-24.76411	3044.571	-32.4905	-10.35808	1.746537	17231.76	3994.476	-1.398601	418.3005	-0.146461	-5.644034			
14	130	31.39011	6.520066	-24.84983	3044.725	-32.60297	-10.39446	0.448184	17233.51	3994.678	-1.196175	418.3217	-0.125263	-2.727284			
15	140	23.50764	-1.384253	-24.87183	3044.764	-32.63183	-10.40379	-0.884221	17233.95	3994.73	-1.144231	418.3271	-0.119824	0.579028			

16	150	16.09997	-8.748177	-24.82843	3044.686	-32.57489	-10.38537	-2.067386	17233.07	3994.627	-1.246711	418.3164	-0.130555	3.659236			
17	160	9.803822	-14.94232	-24.72696	3044.504	-32.44176	-10.34231	-3.050115	17231	3994.388	-1.486329	418.2913	-0.155648	6.249783			
18	170	4.586322	-20.00942	-24.57723	3044.234	-32.24532	-10.27878	-3.875861	17227.95	3994.034	-1.839874	418.2543	-0.192671	8.368411			
19	180	3.14E-15	-24.40467	-24.38696	3043.892	-31.99568	-10.19805	-4.646978	17224.08	3993.585	-2.289178	418.2072	-0.239722	10.20546			
20	190	-4.670173	-28.84577	-24.1588	3043.481	-31.69634	-10.10128	-5.490196	17219.43	3993.046	-2.82794	418.1508	-0.296141	12.06099			
21	200	-10.16228	-34.06724	-23.8892	3042.996	-31.34262	-9.986961	-6.524887	17213.94	3992.41	-3.464557	418.0842	-0.362808	14.24192			
22	210	-17.11917	-40.70246	-23.56874	3042.419	-30.92217	-9.851122	-7.813146	17207.41	3991.653	-4.221284	418.0049	-0.442052	17.01258			
23	220	-25.63151	-48.82959	-23.18492	3041.728	-30.41861	-9.688497	-9.339953	17199.6	3990.747	-5.127605	417.91	-0.536962	20.40487			
24	230	-35.46087	-58.19839	-22.72599	3040.902	-29.81649	-9.494139	-10.94791	17190.26	3989.663	-6.211306	417.7965	-0.650446	24.31329			
25	240	-45.05792	-67.25547	-22.18789	3039.934	-29.1105	-9.266386	-12.31052	17179.31	3988.392	-7.481952	417.6635	-0.783508	28.08808			
26	250	-52.22254	-73.81273	-21.58261	3038.845	-28.31637	-9.010371	-13.01414	17167	3986.963	-8.911228	417.5138	-0.933182	30.81556			
27	260	-54.37049	-75.31838	-20.94249	3037.692	-27.47654	-8.739821	-12.86312	17153.99	3985.451	-10.42275	417.3555	-1.091468	31.43222			
28	270	-51.76928	-72.08208	-20.30957	3036.553	-26.64615	-8.472508	-11.51081	17141.13	3983.957	-11.9173	417.199	-1.247977	30.07036			
29	280	-40.07783	-59.82208	-19.74299	3035.534	-25.90279	-8.233381	-9.273467	17129.61	3982.619	-13.2552	417.0589	-1.388082	24.94749			
30	290	-27.15798	-46.44402	-19.28639	3034.712	-25.30374	-8.04079	-6.740035	17120.34	3981.541	-14.33339	416.946	-1.500989	19.36322			
31	300	-11.83821	-30.79109	-18.95445	3034.114	-24.86824	-7.900846	-4.833058	17113.6	3980.757	-15.1172	416.8639	-1.58307	12.83475			
32	310	-5.877769	-24.59167	-18.71639	3033.686	-24.5559	-7.800513	-4.954187	17108.77	3980.195	-15.67935	416.805	-1.641937	10.24918			
33	320	-13.71023	-32.17913	-18.47233	3033.247	-24.23569	-7.697679	-7.002642	17103.81	3979.618	-16.25566	416.7447	-1.702289	13.40949			
34	330	-29.94264	-48.06524	-18.1273	3032.626	-23.78301	-7.552351	-9.240667	17096.81	3978.804	-17.07041	416.6594	-1.787609	20.02536			
35	340	-40.15942	-57.825	-17.67188	3031.806	-23.1855	-7.360621	-9.661104	17087.57	3977.728	-18.14581	416.5467	-1.900225	24.08504			
36	350	-35.69545	-52.88309	-17.19561	3030.949	-22.56063	-7.160222	-6.088529	17077.91	3976.604	-19.27045	416.429	-2.017997	22.02043			
37	360	-8.44E-14	-16.88631	-16.89539	3030.408	-22.16674	-7.033957	6.608148	17071.82	3975.895	-19.97937	416.3547	-2.092235	7.030178			
38	370	109.8232	92.61011	-17.22123	3030.995	-22.59424	-7.170999	29.63092	17078.43	3976.664	-19.20995	416.4353	-2.011661	-38.56328			
39	380	265.613	246.9352	-18.68151	3033.623	-24.51014	-7.785814	48.56289	17108.06	3980.112	-15.76171	416.7964	-1.650562	-102.9141			
40	390	330.6303	309.5545	-21.07209	3037.926	-27.64657	-8.794578	51.73223	17156.62	3985.757	-10.11674	417.3875	-1.059423	-129.1947			
41	400	306.8797	283.2532	-23.61495	3042.502	-30.98281	-9.870709	44.22083	17208.35	3991.762	-4.112155	418.0163	-0.430624	-118.3957			
42	410	249.284	223.4802	-25.78557	3046.409	-33.83066	-10.79184	35.62458	17252.58	3996.888	1.01343	418.5531	0.106126	-93.53143			
43	420	212.3032	184.7474	-27.53221	3049.553	-36.12225	-11.53473	30.13481	17288.2	4001.012	5.137858	418.985	0.538035	-77.40068			
44	430	189.6085	160.5722	-29.00829	3052.209	-38.05887	-12.16373	25.08203	17318.33	4004.498	8.623393	419.35	0.90304	-67.33097			
45	440	157.1145	126.8468	-30.2359	3054.419	-39.66949	-12.68767	20.34689	17343.42	4007.396	11.52219	419.6536	1.206601	-53.22779			
46	450	137.5773	106.3114	-31.23109	3056.21	-40.97518	-13.11296	17.22038	17363.76	4009.746	13.87219	419.8997	1.452692	-44.63682			
47	460	123.1299	91.01961	-32.07291	3057.725	-42.07965	-13.47309	14.12451	17380.98	4011.734	15.86002	420.1078	1.660857	-38.23523			
48	470	103.6379	70.8354	-32.76308	3058.967	-42.98514	-13.7686	10.56184	17395.11	4013.364	17.48974	420.2785	1.831521	-29.7684			
49	480	83.51433	50.19441	-33.27898	3059.896	-43.66201	-13.98965	6.922016	17405.67	4014.582	18.70795	420.4061	1.959092	-21.10048			
50	490	62.78496	29.12605	-33.617	3060.504	-44.10549	-14.13456	3.498904	17412.59	4015.38	19.50615	420.4896	2.042679	-12.2463			
51	500	44.79865	10.96844	-33.78784	3060.812	-44.32963	-14.20782	0.605556	17416.09	4015.784	19.90956	420.5319	2.084924	-4.612238			
52	510	29.83052	-4.029277	-33.81741	3060.865	-44.36842	-14.2205	-1.735974	17416.7	4015.854	19.97937	420.5392	2.092235	1.694344			
53	520	17.91122	-15.86352	-33.73265	3060.712	-44.25722	-14.18415	-3.61824	17414.96	4015.653	19.77923	420.5182	2.071276	6.670407			
54	530	7.999066	-25.59845	-33.55598	3060.394	-44.02543	-14.1084	-5.143835	17411.34	4015.236	19.36205	420.4745	2.027589	10.76271			
55	540	1.56E-14	-33.34555	-33.30478	3059.942	-43.69586	-14.00071	-6.401305	17406.2	4014.643	18.76889	420.4124	1.965474	14.01785			
56	550	-6.976081	-40.00801	-32.99213	3059.379	-43.28566	-13.86673	-7.511719	17399.8	4013.905	18.03061	420.3351	1.888161	16.81553			
57	560	-13.40613	-46.06996	-32.62517	3058.719	-42.80421	-13.70953	-8.697097	17392.29	4013.038	17.16409	420.2444	1.79742	19.35921			
58	570	-21.35389	-53.59144	-32.2002	3057.954	-42.24666	-13.52757	-10.05534	17383.59	4012.035	16.1606	420.1393	1.692334	22.51421			
59	580	-29.88971	-61.63426	-31.70874	3057.07	-41.60185	-13.31725	-11.44742	17373.53	4010.874	15.00007	420.0178	1.570804	25.88558			
60	590	-38.36039	-69.54353	-31.14905	3056.062	-40.86755	-13.07788	-12.73387	17362.09	4009.553	13.67847	419.8794	1.432406	29.19774			

61	600	-45.81742	-76.37583	-30.52626	3054.941	-40.05044	-12.8117	-13.58649	17349.35	4008.082	12.20784	419.7254	1.278402	32.05451			
62	610	-49.42224	-79.31384	-29.86151	3053.745	-39.1783	-12.5278	-13.44209	17335.77	4006.512	10.63814	419.561	1.114024	33.27454			
63	620	-45.48953	-74.72114	-29.20358	3052.561	-38.31508	-12.24703	-12.10365	17322.32	4004.959	9.084525	419.3983	0.951329	31.33561			
64	630	-35.33928	-63.97642	-28.61093	3051.494	-37.53753	-11.9943	-9.37623	17310.22	4003.559	7.685086	419.2517	0.80478	26.82025			
65	640	-15.29081	-43.46727	-28.15169	3050.668	-36.93501	-11.79858	-5.336228	17300.84	4002.475	6.600658	419.1382	0.691219	18.21745			
66	650	10.23284	-17.68139	-27.89027	3050.197	-36.59203	-11.68721	-0.635853	17295.51	4001.857	5.983354	419.0735	0.626575	7.409259			
67	660	38.27803	10.39505	-27.85912	3050.141	-36.55115	-11.67394	3.842397	17294.87	4001.784	5.909791	419.0658	0.618872	-4.355891			
68	670	61.70739	33.63558	-28.04736	3050.48	-36.79813	-11.75413	7.089017	17298.71	4002.228	6.354304	419.1124	0.665421	-14.09605			
69	680	76.01871	47.59857	-28.39461	3051.105	-37.25372	-11.90209	8.334256	17305.8	4003.048	7.174277	419.1982	0.751288	-19.95177			
70	690	76.73453	47.90497	-28.80277	3051.839	-37.78922	-12.07609	7.072332	17314.14	4004.012	8.138069	419.2992	0.852217	-20.08504			
71	700	62.3149	33.13798	-29.14904	3052.463	-38.24353	-12.22376	3.37711	17321.21	4004.83	8.955748	419.3848	0.937844	-13.89654			
72	710	34.90361	5.560849	-29.31437	3052.76	-38.46044	-12.29429	-2.066507	17324.59	4005.22	9.346139	419.4257	0.978725	-2.332191			
73	720	1.02E-13	-29.24128	-29.2132	3052.578	-38.32771	-12.25114		17322.52	4004.981	9.107257	419.4007	0.95371	12.26291			
74																	
75																	
76																	
77																	
78																	
79																	
80																	
81																	
82																	
83																	
84																	
85																	
86																	
87																	
88																	
89																	
90																	
91																	
92																	
93																	
94																	
95																	
96																	
97																	
98																	
99																	
100																	

? **Ergänzungskapitel**

4.0 Motormomentkurven, Leistungswerte, Trägheitsmomente, Gewicht, Wirkungsgrad

4.1 Parameter des Asynchron-Elektromotors (Generators) 4.18 Drehmoment- und Leistungskurve

4.2 Typ des Motors/Generators	3000 / 2p ... 50Hz	
4.3 Nennleistung	Pr	10 [kW]
4.4 Betriebsart	Als Motor-Generator	
4.5 Synchrondrehzahl	ns	3000 [/min]
4.6 Nenndrehzahl	nr	2931 2931 [/min]
4.7 Nenndrehmoment	Tr	32.58273627 [Nm]
4.8 Anlaufmoment-Koeffizient	Tzcoeff	2.5 2.5 [~]
4.9 Anlaufmoment	Tz	81.45684067 [Nm]
4.10 Motorgewicht (ungefähr)	m	120 [kg]
4.11 Trägheitsmoment (ungefähr)	Ie	0.04529 [kg*m ²]
4.12 Nennwirkungsgrad IE1/IE2	ηN	87.1 89 [%]
4.13 Nennwirkungsgrad IE3/IE4	ηN	90.9 92.3 [%]
4.14 Berechnung von Moment und Leistung für die angegebene Drehzahl		
4.15 Geschwindigkeit	n	2950 [/min]
4.16 Drehmoment	T	23.61067845 [Nm]
4.17 Leistung	Pw	7.293350936 [kW]

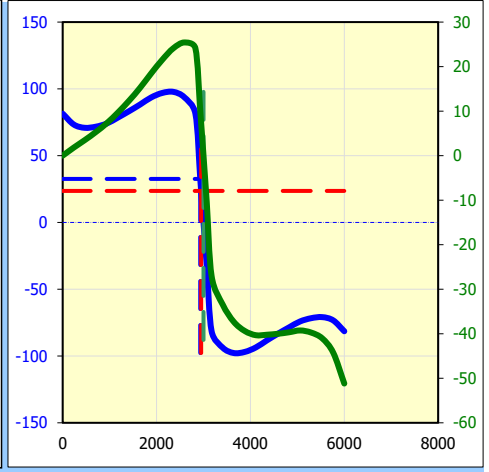
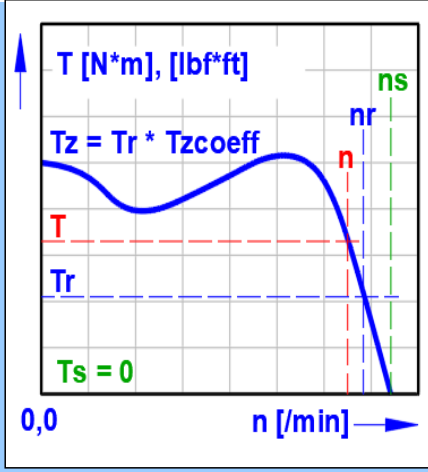

5.0 Kurbeltrieb

5.1 Parameter des Kurbeltriebs

5.2 Gewicht des Gleitteils	mp	0.4	[kg]
5.3 Pleuelstangengewicht (gesamt)	m	1	[kg]
5.4 Länge der Pleuelstange	L	100.00	[mm]
5.5 Schwerpunktposition (T)	Ls	70.00 < 100	[mm]
5.6 Verteiltes Pleuelstangengewicht	ms, mr	0.3 0.7	[kg]
5.7 Kurbelradius	R	31.00	[mm]
5.8 Kurbeldrehzahl	n	4000	[/min]
5.9 Winkelgeschwindigkeit der Kurbel	ω	418.8790205	[rad/s]
5.10 Kurbelverhältnis (R/L)	λ	0.31	[~]
5.11 Zentrifugalkraft für mr	Fc	3807.474053	[N]
5.12 Mittlere Kolbengeschwindigkeit	vs	8.266666667	[m/s]
5.13 Drehwinkel	α	45	[°]

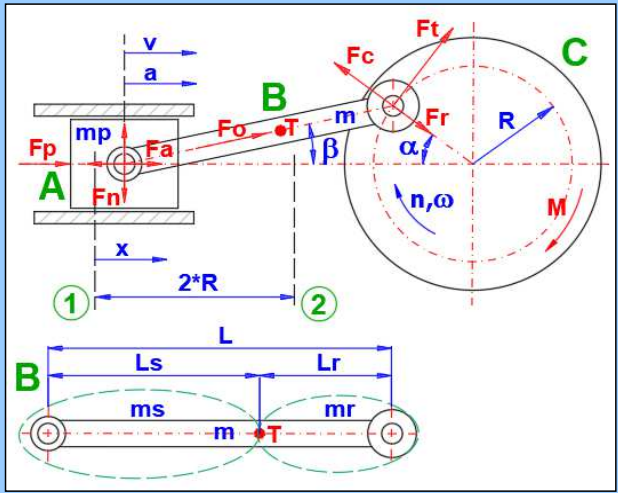

5.15 Momentendiagramme

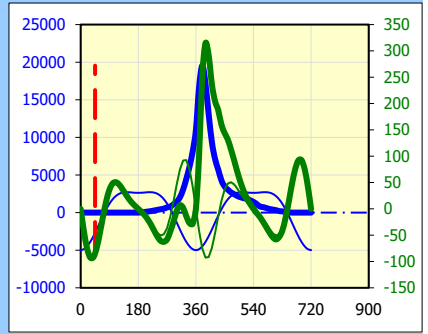
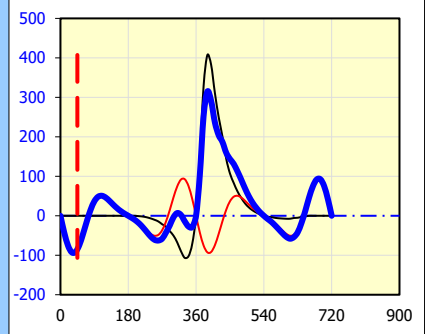

5.16 Diagramme für ausgewählte Werte

Blaue Kurve (links, stark)	1.	05. Fp [N]
Blaue Kurve (links, schwach)	2.	06. Fa [N]
Grüne Kurve (rechts, stark)	3.	20. ΣM [Nm]
Grüne Kurve (rechts, schwach)	4.	19. Ma [Nm]

5.14 Tabelle

	A	B	C	D	E	F	G	H	I	J	K	L	M	Diagramme für ausgewählte Werte			
	α	Fp	x	v	a	Fa	Fn	Fo	Ft	Fr	Mp	Ma	M	1. Fp	2. Fa	3. ΣM	4. Ma
ID	[°]	[N]	[mm]	[m/s]	[m/s ²]	[N]	[N]	[N]	[N]	[N]	[Nm]	[Nm]	[Nm]	[N]	[N]	[Nm]	[Nm]
1	0	0	0	0	7125.416	-4987.791	0	-4987.791	0	-4987.791	0	0	0	0	-4987.791	0	0

2	10	0	0.615848	2.943254	6941.093	-4858.765	-261.9317	-4865.82	-1358.872	-4739.466	0	-42.12504	-42.12504	0	-4858.765	-42.12504	-42.12504
3	20	0	2.431607	5.734964	6402.901	-4482.031	-477.9067	-4507.437	-2426.053	-4048.277	0	-75.20764	-75.20764	0	-4482.031	-75.20764	-75.20764
4	30	0	5.354462	8.235686	5553.611	-3887.528	-609.9382	-3935.085	-2987.44	-3061.729	0	-92.61065	-92.61065	0	-3887.528	-92.61065	-92.61065
5	40	0	9.237933	10.32889	4459.506	-3121.654	-634.7635	-3185.538	-2959.572	-1983.308	0	-91.74672	-91.74672	0	-3121.654	-91.74672	-91.74672
6	50	0	13.89327	11.92941	3203.482	-2242.437	-548.2019	-2308.474	-2402.401	-1021.464	0	-74.47444	-74.47444	0	-2242.437	-74.47444	-74.47444
7	60	0	19.10375	12.98862	1876.541	-1313.579	-366.0934	-1363.64	-1490.246	-339.7431	0	-46.19763	-46.19763	0	-1313.579	-46.19763	-46.19763
8	70	0	24.6403	13.49589	568.6537	-398.0576	-121.213	-416.1039	-453.3704	-22.24073	0	-14.05448	-14.05448	0	-398.0576	-14.05448	-14.05448
9	80	0	30.27702	13.47636	-639.9631	447.9742	143.6187	470.433	488.6655	-63.64689	0	15.14863	15.14863	0	447.9742	15.14863	15.14863
10	90	0	35.805	12.98525	-1686.167	1180.317	384.8577	1241.476	1180.317	-384.8577	0	36.58983	36.58983	0	1180.317	36.58983	36.58983
11	100	0	41.04321	12.09959	-2528.994	1770.296	567.5496	1859.048	1555.703	-866.3359	0	48.22681	48.22681	0	1770.296	48.22681	48.22681
12	110	0	45.84555	10.9084	-3152.012	2206.408	671.8761	2306.438	1633.687	-1385.993	0	50.64431	50.64431	0	2206.408	50.64431	50.64431
13	120	0	50.10375	9.502495	-3562.708	2493.896	695.0469	2588.939	1490.246	-1848.876	0	46.19763	46.19763	0	2493.896	46.19763	46.19763
14	130	0	53.74611	7.965142	-3789.081	2652.357	648.4138	2730.465	1222.084	-2201.616	0	37.88461	37.88461	0	2652.357	37.88461	37.88461
15	140	0	56.73269	6.364622	-3873.906	2711.734	551.4096	2767.229	915.2028	-2431.748	0	28.37129	28.37129	0	2711.734	28.37129	28.37129
16	150	0	59.04804	4.749564	-3867.444	2707.211	424.751	2740.329	626.8063	-2556.889	0	19.43099	19.43099	0	2707.211	19.43099	19.43099
17	160	0	60.69255	3.14747	-3819.543	2673.68	285.0872	2688.836	381.6838	-2609.943	0	11.8322	11.8322	0	2673.68	11.8322	11.8322
18	170	0	61.67393	1.566476	-3772.135	2640.495	142.3467	2644.329	178.5554	-2625.098	0	5.535216	5.535216	0	2640.495	5.535216	5.535216
19	180	0	62	1.1E-15	-3753.082	2627.157	9.98E-14	2627.157	1.22E-13	-2627.157	0	3.79E-15	3.79E-15	0	2627.157	3.79E-15	3.79E-15
20	190	40	61.67393	-1.566476	-3772.135	2640.495	-144.5031	2684.387	-181.2602	-2664.865	-0.083851	-5.535216	-5.619068	40	2640.495	-5.619068	-5.535216
21	200	81	60.69255	-3.14747	-3819.543	2673.68	-293.724	2770.295	-393.2471	-2689.012	-0.35846	-11.8322	-12.19066	81	2673.68	-12.19066	-11.8322
22	210	142	59.04804	-4.749564	-3867.444	2707.211	-447.0303	2884.066	-659.6838	-2691.004	-1.019204	-19.43099	-20.4502	142	2707.211	-20.4502	-19.43099
23	220	203	56.73269	-6.364622	-3873.906	2711.734	-592.688	2974.383	-983.7147	-2613.789	-2.12387	-28.37129	-30.49516	203	2711.734	-30.49516	-28.37129
24	230	285	53.74611	-7.965142	-3789.081	2652.357	-718.0869	3023.858	-1353.399	-2438.183	-4.070762	-37.88461	-41.95537	285	2652.357	-41.95537	-37.88461
25	240	366	50.10375	-9.502495	-3562.708	2493.896	-797.0509	2968.887	-1708.952	-2120.214	-6.779888	-46.19763	-52.97751	366	2493.896	-52.97751	-46.19763
26	250	447	45.84555	-10.9084	-3152.012	2206.408	-807.9927	2773.703	-1964.659	-1666.784	-10.26012	-50.64431	-60.90442	447	2206.408	-60.90442	-50.64431
27	260	529	41.04321	-12.09959	-2528.994	1770.296	-737.1448	2414.569	-2020.579	-1125.215	-14.41114	-48.22681	-62.63794	529	1770.296	-62.63794	-48.22681
28	270	692	35.805	-12.98525	-1686.167	1180.317	-610.4933	1969.333	-1872.317	-610.4933	-21.452	-36.58983	-58.04183	692	1180.317	-58.04183	-36.58983
29	280	814	30.27702	-13.47636	-639.9631	447.9742	-404.5837	1325.242	-1376.604	-179.2977	-27.52611	-15.14863	-42.67474	814	447.9742	-42.67474	-15.14863
30	290	1099	24.6403	-13.49589	568.6537	-398.0576	-213.4449	732.7203	-798.3431	39.16386	-38.80312	14.05448	-24.74864	1099	-398.0576	-24.74864	14.05448
31	300	1425	19.10375	-12.98862	1876.541	-1313.579	-31.05308	115.6678	-126.4069	28.81797	-50.11624	46.19763	-3.918614	1425	-1313.579	-3.918614	46.19763
32	310	2035	13.89327	-11.92941	3203.482	-2242.437	50.71157	-213.546	222.2348	-94.49078	-67.58516	74.47444	6.889278	2035	-2242.437	6.889278	74.47444
33	320	3053	9.237933	-10.32889	4459.506	-3121.654	13.96029	-70.05921	65.08957	-43.61869	-89.72895	91.74672	2.017777	3053	-3121.654	2.017777	91.74672
34	330	4478	5.354462	-8.235686	5553.611	-3887.528	-92.64284	597.6957	-453.759	465.0426	-106.6772	92.61065	-14.06653	4478	-3887.528	-14.06653	92.61065
35	340	6107	2.431607	-5.734964	6402.901	-4482.031	-173.2661	1634.181	-879.5705	1467.711	-102.4743	75.20764	-27.26668	6107	-4482.031	-27.26668	75.20764
36	350	8143	0.615848	-2.943254	6941.093	-4858.765	-177.0501	3289.004	-918.5165	3203.596	-70.59905	42.12504	-28.47401	8143	-4858.765	-28.47401	42.12504
37	360	10993	2.88E-31	-4.17E-15	7125.416	-4987.791	-4.56E-13	6005.209	-2.38E-12	6005.209	-1.35E-13	6.14E-14	-7.39E-14	10993	-4987.791	-7.39E-14	6.14E-14
38	370	16693	0.615848	2.943254	6941.093	-4858.765	637.973	11851.42	3309.733	11543.66	144.7268	-42.12504	102.6017	16693	-4858.765	102.6017	-42.12504
39	380	19543	2.431607	5.734964	6402.901	-4482.031	1605.91	15146.34	8152.266	13603.43	327.9279	-75.20764	252.7203	19543	-4482.031	252.7203	-75.20764
40	390	17100	5.354462	8.235686	5553.611	-3887.528	2072.986	13374.11	10153.36	10405.84	407.3648	-92.61065	314.7542	17100	-3887.528	314.7542	-92.61065
41	400	13028	9.237933	10.32889	4459.506	-3121.654	2014.376	10109.08	9391.989	6293.885	382.8984	-91.74672	291.1516	13028	-3121.654	291.1516	-91.74672
42	410	9364	13.89327	11.92941	3203.482	-2242.437	1740.987	7331.282	7629.578	3243.979	310.9914	-74.47444	236.5169	9364	-2242.437	236.5169	-74.47444
43	420	7125	19.10375	12.98862	1876.541	-1313.579	1619.639	6032.897	6593.019	1503.062	250.5812	-46.19763	204.3836	7125	-1313.579	204.3836	-46.19763
44	430	5700	24.6403	13.49589	568.6537	-398.0576	1614.501	5542.311	6038.683	296.2362	201.2537	-14.05448	187.1992	5700	-398.0576	187.1992	-14.05448
45	440	4275	30.27702	13.47636	-639.9631	447.9742	1514.166	4959.756	5151.981	-671.0266	144.5628	15.14863	159.7114	4275	447.9742	159.7114	15.14863
46	450	3460	35.805	12.98525	-1686.167	1180.317	1513.036	4880.76	4640.317	-1513.036	107.26	36.58983	143.8498	3460	1180.317	143.8498	36.58983

47	460	3053	41.04321	12.09959	-2528.994	1770.296	1546.329	5065.108	4238.623	-2360.393	83.17052	48.22681	131.3973	3053	1770.296	131.3973	48.22681
48	470	2687	45.84555	10.9084	-3152.012	2206.408	1490.098	5115.255	3623.219	-3073.878	61.67547	50.64431	112.3198	2687	2206.408	112.3198	50.64431
49	480	2442	50.10375	9.502495	-3562.708	2493.896	1375.631	5124.005	2949.482	-3659.279	45.2363	46.19763	91.43393	2442	2493.896	91.43393	46.19763
50	490	2198	53.74611	7.965142	-3789.081	2652.357	1185.752	4993.193	2234.822	-4026.088	31.39486	37.88461	69.27947	2198	2652.357	69.27947	37.88461
51	500	2035	56.73269	6.364622	-3873.906	2711.734	965.2106	4843.874	1602.01	-4256.635	21.29101	28.37129	49.6623	2035	2711.734	49.6623	28.37129
52	510	1913	59.04804	4.749564	-3867.444	2707.211	724.8934	4676.732	1069.727	-4363.667	13.73055	19.43099	33.16154	1913	2707.211	33.16154	19.43099
53	520	1832	60.69255	3.14747	-3819.543	2673.68	480.4283	4531.221	643.2128	-4398.27	8.107398	11.8322	19.9396	1832	2673.68	19.9396	11.8322
54	530	1628	61.67393	1.566476	-3772.135	2640.495	230.1107	4274.693	288.6439	-4243.605	3.412744	5.535216	8.94796	1628	2640.495	8.94796	5.535216
55	540	1425	62	3.29E-15	-3753.082	2627.157	4.62E-13	4052.157	5.66E-13	-4052.157	6.17E-15	1.14E-14	1.75E-14	1425	2627.157	1.75E-14	1.14E-14
56	550	1140	61.67393	-1.566476	-3772.135	2640.495	-203.8031	3785.984	-255.6444	-3758.451	-2.389759	-5.535216	-7.924975	1140	2640.495	-7.924975	-5.535216
57	560	814	60.69255	-3.14747	-3819.543	2673.68	-371.8818	3507.45	-497.8872	-3404.538	-3.602305	-11.8322	-15.4345	814	2673.68	-15.4345	-11.8322
58	570	732	59.04804	-4.749564	-3867.444	2707.211	-539.599	3481.284	-796.2878	-3248.243	-5.253927	-19.43099	-24.68492	732	2707.211	-24.68492	-19.43099
59	580	610	56.73269	-6.364622	-3873.906	2711.734	-675.4482	3389.712	-1121.076	-2978.766	-6.382072	-28.37129	-34.75336	610	2711.734	-34.75336	-28.37129
60	590	488	53.74611	-7.965142	-3789.081	2652.357	-767.7137	3232.836	-1446.932	-2606.685	-6.970287	-37.88461	-44.8549	488	2652.357	-44.8549	-37.88461
61	600	407	50.10375	-9.502495	-3562.708	2493.896	-808.4776	3011.45	-1733.452	-2150.61	-7.539383	-46.19763	-53.73701	407	2493.896	-53.73701	-46.19763
62	610	325	45.84555	-10.9084	-3152.012	2206.408	-770.8423	2646.172	-1874.327	-1590.147	-7.459817	-50.64431	-58.10412	325	2206.408	-58.10412	-50.64431
63	620	203	41.04321	-12.09959	-2528.994	1770.296	-632.6306	2072.226	-1734.096	-965.6788	-5.530172	-48.22681	-53.75698	203	1770.296	-53.75698	-48.22681
64	630	162	35.805	-12.98525	-1686.167	1180.317	-437.6799	1411.871	-1342.317	-437.6799	-5.022	-36.58983	-41.61183	162	1180.317	-41.61183	-36.58983
65	640	81	30.27702	-13.47636	-639.9631	447.9742	-169.5869	555.4939	-577.023	-75.15513	-2.739084	-15.14863	-17.88771	81	447.9742	-17.88771	-15.14863
66	650	40	24.6403	-13.49589	568.6537	-398.0576	109.0326	-374.2904	407.8121	-20.0058	-1.412306	14.05448	12.64218	40	-398.0576	12.64218	14.05448
67	660	0	19.10375	-12.98862	1876.541	-1313.579	366.0934	-1363.64	1490.246	-339.7431	0	46.19763	46.19763	0	-1313.579	46.19763	46.19763
68	670	0	13.89327	-11.92941	3203.482	-2242.437	548.2019	-2308.474	2402.401	-1021.464	0	74.47444	74.47444	0	-2242.437	74.47444	74.47444
69	680	0	9.237933	-10.32889	4459.506	-3121.654	634.7635	-3185.538	2959.572	-1983.308	0	91.74672	91.74672	0	-3121.654	91.74672	91.74672
70	690	0	5.354462	-8.235686	5553.611	-3887.528	609.9382	-3935.085	2987.44	-3061.729	0	92.61065	92.61065	0	-3887.528	92.61065	92.61065
71	700	0	2.431607	-5.734964	6402.901	-4482.031	477.9067	-4507.437	2426.053	-4048.277	0	75.20764	75.20764	0	-4482.031	75.20764	75.20764
72	710	0	0.615848	-2.943254	6941.093	-4858.765	261.9317	-4865.82	1358.872	-4739.466	0	42.12504	42.12504	0	-4858.765	42.12504	42.12504
73	720	0	1.15E-30	-8.34E-15	7125.416	-4987.791	7.58E-13	-4987.791	3.96E-12	-4987.791	0	1.23E-13	1.23E-13	0	-4987.791	1.23E-13	1.23E-13